

Double Top Hat	
Ø A =	
B =	
C =	
Quantity =	

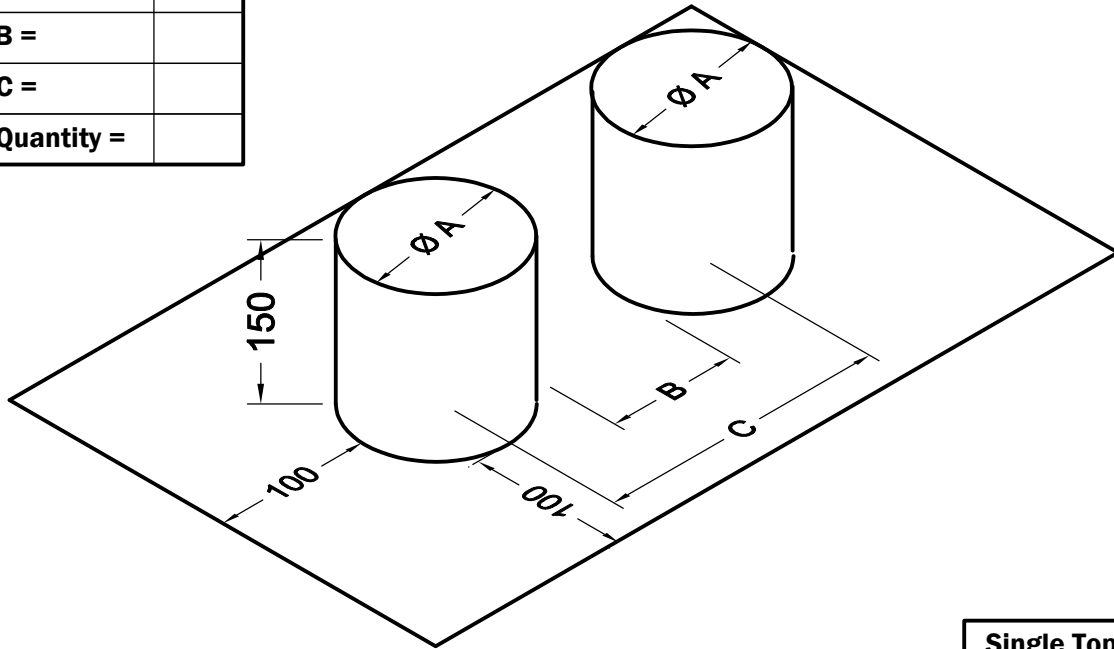

Single Top Hat	
Ø A =	
Quantity =	

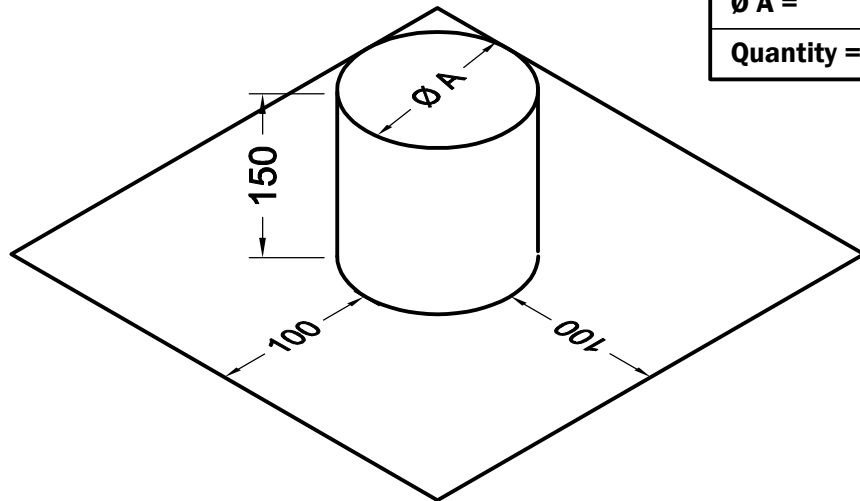

Materials :-

Refer to Cordek technical data sheets for full detailed material specification

A. Cordek Preformed Top Hat

NB : Cordek Puraflex should be installed with welded joints only

Notes :-

- This detail is issued for guidance purposes only, with final approval required from the designer
- Do not scale from drawing, use dimensions provided
- All laps and junctions must be fully sealed with appropriate welding techniques or jointing system
- The intended construction sequence should be considered prior to selection of the appropriate Cordek standard detail to ensure that installation is practical and achievable
- In accordance with BS8102:2009, should hydrostatic water pressure be a risk, additional waterproofing methods should be considered.

Standard Detail



Tel : 01403 799600

Email : techsupport@cordek.com

Drg. Title:
Cordek VOC / Hydrocarbon Protection System
Typical Preformed Top Hat Detail

Drawn: SP

Date: 20.03.19

Scale: NTS

Drg. No. ENG/GP/MEM/PUR/24

Rev: B